

SECCION A-A

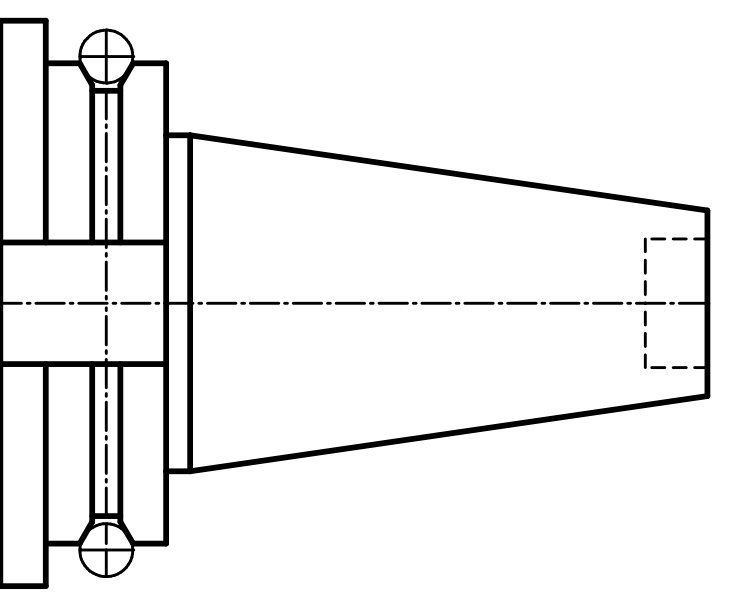
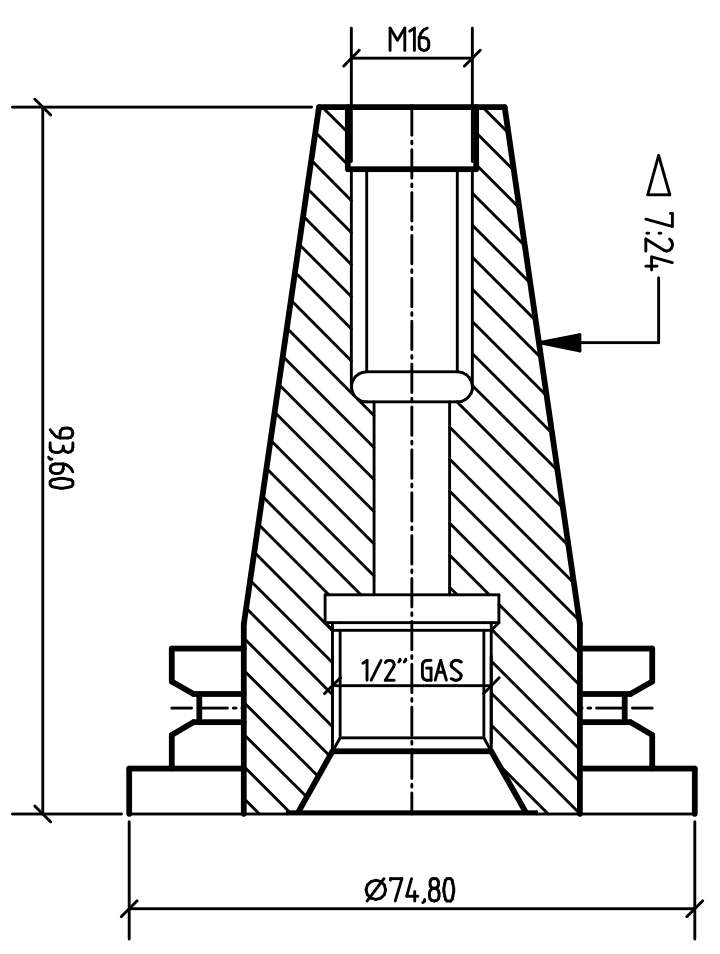
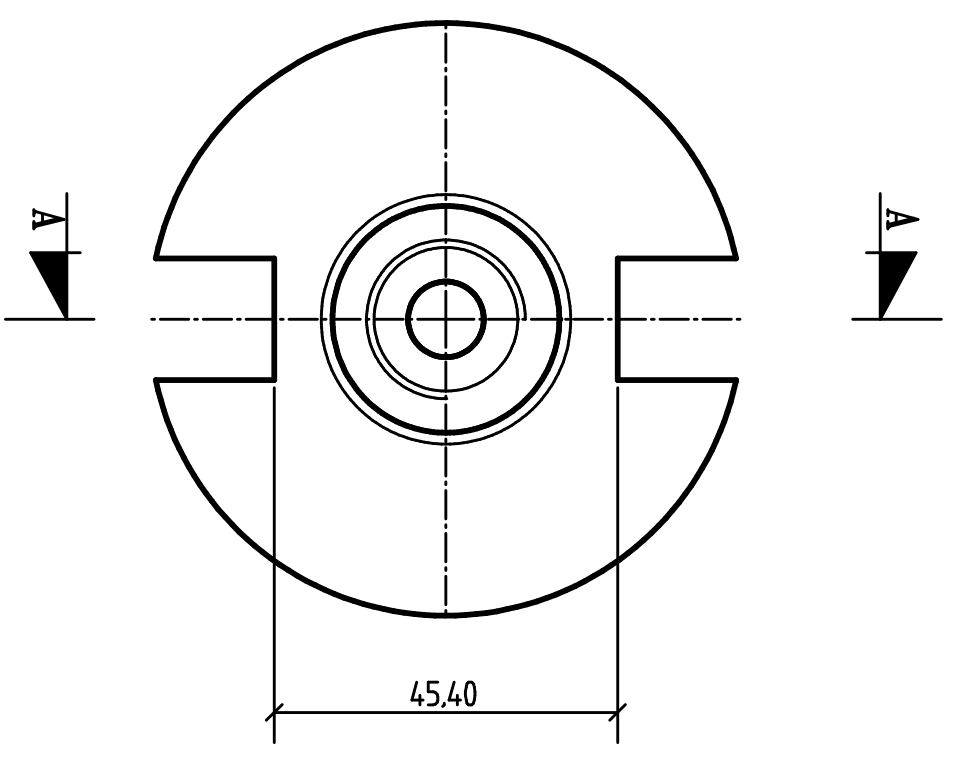

Rev	Fecha	Modificacion		
Pos.	Ø75x95mm	A. INOX AISI 304	DIN 69871-A	3.3 Kg
DENOMINACION	Material	Nº Plano	Norma o Especific.	Peso Neto
Pertenece a:				
ESCALA 1/1	DIBUJADO	FECHA	NOMBRE	
	COMPROBADO	05/7/2013		
	VISADO			
CONO ISO-40	Unificado Maquina		PLANO Nº	T-010
			Modelo de Maquina:	
	Conjunto:		Archivo Hoja:	1106-A
TECHNIKA I-MAQ CREATIVE				